

LIFT RANGE

GEARLESS MACHINES FOR ELEVATORS

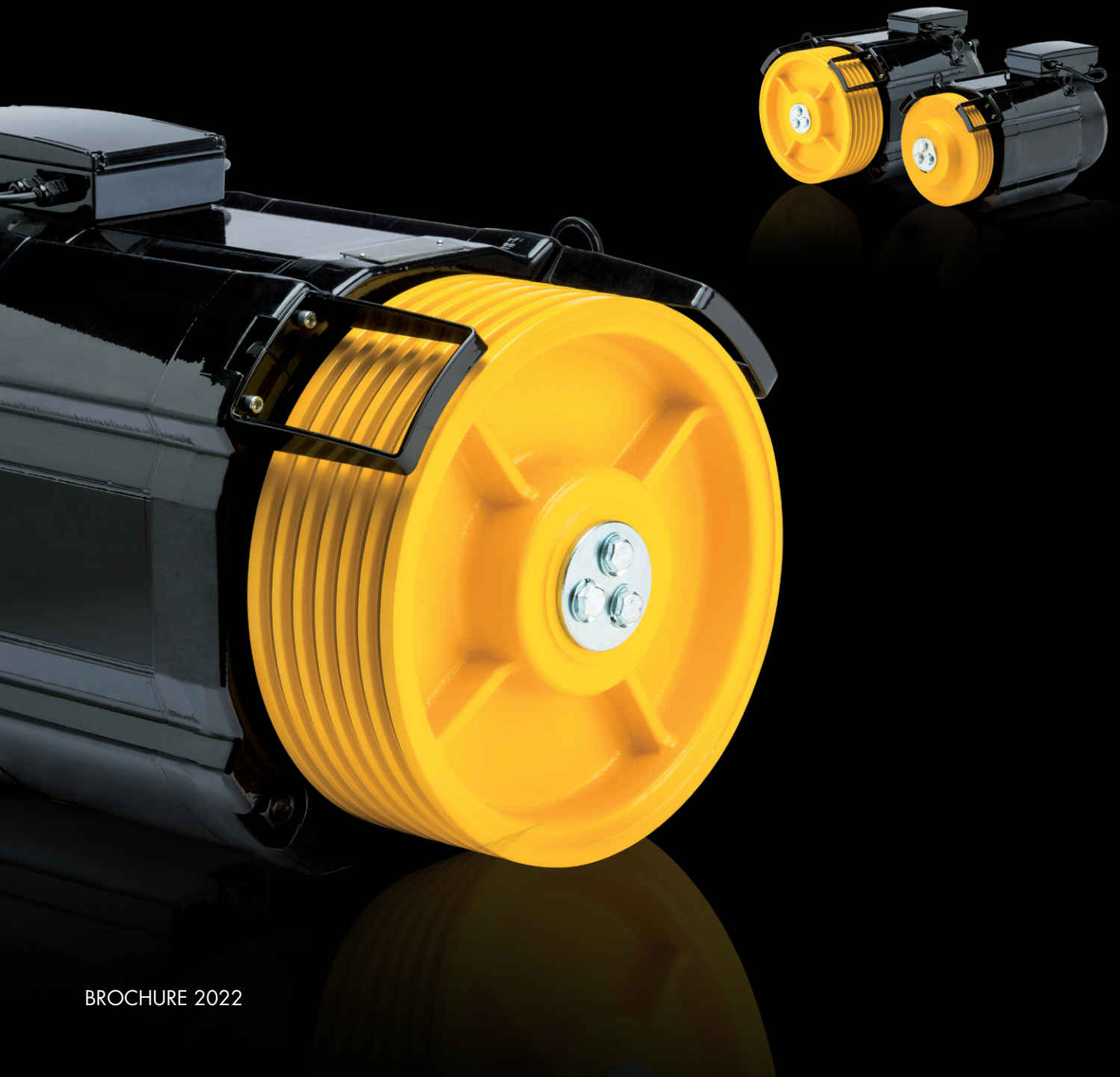

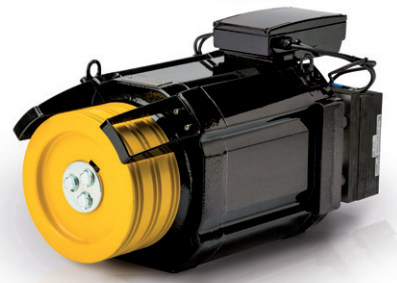

GEARLESS MACHINES FOR ELEVATORS

COMPACT DESIGN FOR M.R.L. SYSTEMS

STANDARD FEATURES

- Full range properly intercalated within the torque range 140 to 850 Nm for payload 240 to 1.600 kg in roping 2:1 and 320 to 800 kg in roping 1:1
- Motor protection class: IP44
- TENV execution
- Insulation class F
- Poles: series M/T24 S/.../L = 24 poles - series T32 S/.../L/XL = 30 poles
- Winding thermal protection always present (3xPTC)
- Service: S3 40%
- In accordance with UNI EN81-1:1998+A3:2009 certified by TÜV SÜD
- Possible power supply with single-phase and three-phase drive
- Windings designed for speeds from 0,5m/s to 2,5 m/s
- Traction sheaves LC in both hardened steel (HRC \geq 50) and spheroidal cast iron to be machined according to customer specification
- IP64 absolute and incremental encoders (Endat-sincos-HTL-TTL) in IP64, always inside the motor and with a protection cover against damages
- Encoders supplied with 10 m-long outgoing cable without connector
- Brakes according to UNI EN81-1:20/50 and certified as part of the protection system against uncontrolled upward movements of the elevator car
- Brakes certified for EN81-1 A3 amendment (EN81-1:1998+A3:2009)
- Motors supplied with terminal board without outgoing cables

OPTIONAL FEATURES

- Brakes with cURus certification and in compliance with ASME A17 Safety Code for the North America (on request)
- NETEC Certification for the Chinese market: motors up to type T32L with max payload 1275 kg in roping 2:1, and 800 kg in roping 1:1
- Brakes with induction sensors, in order to guarantee maximum reliability even in very critical environments and for heavy lifting applications
- Brakes with release levers (even fitted with reduced overall dimensions)

TARGET APPLICATIONS

- Elevators without machine room (M.R.L)
- Elevators with machine room (modernization)
- Elevators/hoists
- Home lifts

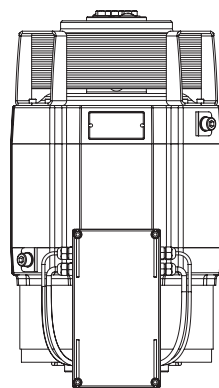

M24S/T24S

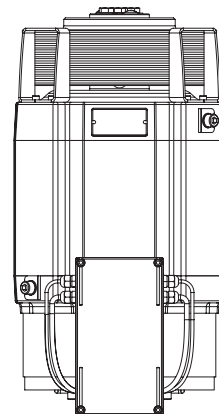

M24/T24

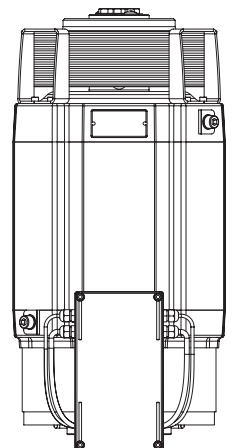

T24L

THE RANGE

RATED TORQUE UP TO 250 Nm - MAX PAYLOAD 630 kg

Because of its own long-term experience in the electric motor sector, Lafert is able to offer the right solution for each environment. Always focused on applications, Lafert takes advantage of its own know how in order to fully meet the most challenging requirements, always offering **high efficiency**, safe and reliable solutions.

For the elevator sector Lafert has developed a range of Lift motors, designed to be installed in the new generation of elevators, without machine room (M.R.L.). This new range is intended to be used to exactly meet the particular needs related to the elevator motorization. They are permanent-magnet gearless synchronous machines with a **compact design**, giving **reduced energy consumption**, **low noise levels**, high passenger comfort and low maintenance.



MOTOR SPECIFICATIONS

Motor size	M24S/T24S		M24/T24		T24L	T32S	T32	T32L	T32XL
Drive supply	230 V (M24S)	380-480 V (T24S)	230 V (M24)	380-480 (T24)	380-480 V	380-480 V	380-480 V	380-480 V	380-480 V
Max payload kg (roping 2:1)	480		630		630	800	1000	1275	1600
Static load	20 kN		20 kN		20 kN	26 kN	26 kN	32 kN	41 kN
Traction sheave Ø mm	160 - 210 - 240		160 - 210 - 240		210 - 240	240 - 320	240 - 320	240 - 320 - 400	320
Car speed m/s	0,6 - 2,0		0,6 - 2,0		1,0 - 2,0	1,0 - 2,5	1,0 - 2,5	1,0 - 2,5	1,0 - 2,5
Motor torque Nm	140		200		250	330	480	660	850
Braking torque Nm	2 x 140		2 x 200		2 x 250	2 x 330	2 x 480	2 x 660	2 x 900
DE Bearing	Locked sealed ball bearing					Locked sealed ball bearing			Locked sealed roll bearing
NDE bearing	Sealed ball bearing					Sealed ball bearing			Locked sealed ball bearing
Poles	24		24		24	30	30	30	30
Thermal class	155° (F)		155° (F)		155° (F)	155° (F)	155° (F)	155° (F)	155° (F)
Degree of protection	IP44		IP44		IP44	IP44	IP44	IP44	IP44
Winding protection	3x PTC 140°C		3x PTC 140°C		3x PTC 140°C	3x PTC 140°C	3x PTC 140°C	3x PTC 140°C	3x PTC 140°C
Standard and Regulations	2014/33/EC Directive - EN81-20/50 2014					2014/33/EC Directive - EN81-20/50 2014			

BRAKE SPECIFICATIONS

Motor size	M24S/T24S	M24/T24	T24L	T32S	T32	T32L	T32XL
Brake Type	EVO-01 FRLF140	EVO-01 FRLF200	EVO-01 FRLF250	EVO-02 FRLF330	EVO-02 FRLF480	EVO-03 FRLF660	EVO-04 FRLF900
Max braking torque Nm	2x140	2x200	2x250	2x330	2x480	2x660	2x900
Holding voltage Vdc	207	207	207	207	207	207	207
Holding power W	2x62	2x62	2x62	2x85	2x85	2x140	2x125
Micro switch	2x3 wires			2X3 wires			
Standard	UNI EN 81-20/50, EN81-1:1998+A3:2009				UNI EN 81-20/50, EN81-1:1998+A3:2009		

ENCODER SPECIFICATIONS

Heidenhain IP64 encoders available in the execution with 5 m outgoing cable without connector:

1. Absolute Sin-Cos 1Vpp (Vsupply 5V) with 2048 r/t => ERN487 or Hohner equivalent type*
2. Absolute EnDat 2.1 13bit (Vsupply 3.6 ... 14V) with 2048 r/t => ECN413 type 3. Incremental TTL (Vsupply 5V±10%) with 4096 r/t => ERN421 type
4. Incremental HTL (Vsupply 10V...30V) with 4096 r/t => ERN431 type

* As Standard

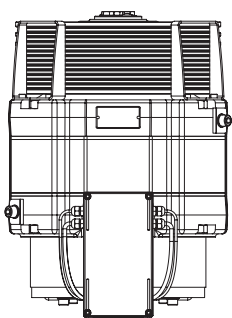

T32S

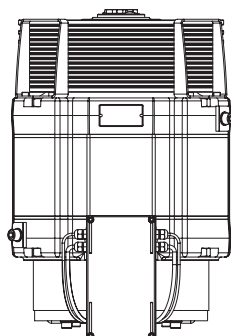

T32

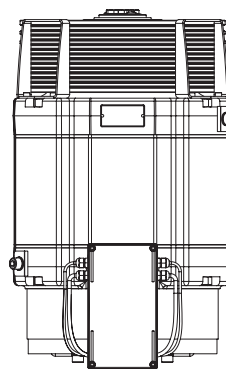

T32L

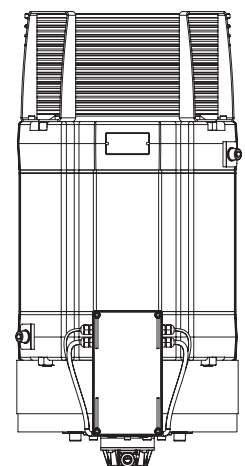

T32XL

RATED TORQUE UP TO 850 Nm - MAX PAYLOAD 1600 kg

PERFORMANCE DATA M24S/T24S - M24/T24 -T24L

	MAX PAYLOAD	ROPING	RATED TORQUE M_N	SPEED	TRACTION SHEAVE Ø	MAX ROPES Ø	POLES	RATED SPEED n	RATED POWER	CURRENT	FREQUENCY SUPPLY	
TYPE	kg		Nm	m/s	mm	mm		min-1	kW	Amp	Hz	
Static load 20 kN												
M24S/T24S	M24S.240.06	240	2:1	140	0.6	240	6 x 6.5	24	95	1.4	7.8	19.0
	M24S.240.10	240	2:1	140	1	240	6 x 6.5	24	160	2.3	10.5	32.0
	M24S.210.06	240	2:1	140	0.6	210	6 x 6.5	24	110	1.6	7.8	22.0
	M24S.210.10	240	2:1	140	1	210	6 x 6.5	24	180	2.7	10.5	36.0
	M24S.240.06	320	2:1	140	0.6	240	6 x 6.5	24	95	1.4	7.8	19.0
	M24S.240.10	320	2:1	140	1	240	6 x 6.5	24	160	2.3	10.5	32.0
	M24S.160.05	480	2:1	140	0.5	160	6 x 6.5	24	119	1.6	8.3	24.0
	M24S.160.10	480	2:1	140	1	160	6 x 6.5	24	239	3.2	11.9	48.0
	T24S.240.10	320	2:1	140	1	240	6 x 6.5	24	160	2.3	6.0	32.0
	T24S.240.16	320	2:1	140	1.6	240	6 x 6.5	24	255	3.7	8.1	51.0
	T24S.240.20	320	2:1	140	2	240	6 x 6.5	24	320	4.6	10.5	64.0
	T24S.210.10	320	2:1	140	1	210	6 x 6.5	24	180	2.7	6.3	36.0
	T24S.210.16	320	2:1	140	1.6	210	6 x 6.5	24	290	4.3	8.6	58.0
	T24S.210.20	320	2:1	140	2	210	6 x 6.5	24	360	5.3	11.9	72.0
	T24S.160.05	480	2:1	140	0.5	160	6 x 6.5	24	119	1.6	7.5	24.0
	T24S.160.10	480	2:1	140	1	160	6 x 6.5	24	239	3.2	8.1	48.0

	MAX PAYLOAD	ROPING	RATED TORQUE M_N	SPEED	TRACTION SHEAVE Ø	MAX ROPES Ø	POLES	RATED SPEED n	RATED POWER	CURRENT	FREQUENCY SUPPLY	
TYPE	kg		Nm	m/s	mm	mm		min-1	kW	Amp	Hz	
Static load 20 kN												
M24/T24	M24.210.06	480	2:1	200	0.6	210	6 x 6.5	24	110	2.3	11.1	22.0
	M24.240.06	480	2:1	200	0.6	240	6 x 6.5	24	95	2.0	10.0	19.0
	M24.210.06	550	2:1	200	0.6	210	6 x 6.5	24	110	2.3	10.0	22.0
	M24.160.05	630	2:1	200	0.5	160	6 x 6.5	24	119	2.0	10.0	24.0
	M24.160.10	630	2:1	200	1	160	6 x 6.5	24	239	5.0	11.0	48.0
	T24.240.10	480	2:1	200	1	240	6 x 6.5	24	160	3.3	9.1	32.0
	T24.240.16	480	2:1	200	1.6	240	6 x 6.5	24	255	5.3	13.1	51.0
	T24.240.20	480	2:1	200	2	240	6 x 6.5	24	320	6.7	14.4	64.0
	T24.210.10	550	2:1	200	1	210	6 x 6.5	24	180	3.8	9.1	36.0
	T24.210.16	550	2:1	200	1.6	210	6 x 6.5	24	290	6.1	13.3	58.0
	T24.210.20	550	2:1	200	2	210	6 x 6.5	24	360	7.6	15.7	72.0
	T24.160.05	630	2:1	200	0.5	160	6 x 6.5	24	119	2.0	6.3	24.0
	T24.160.10	630	2:1	200	1	160	6 x 6.5	24	239	4.1	10.0	48.0
	T24.210.10D	320	1:1	200	1	210	6 x 6.5	24	90	1.4	5.8	18.0
	T24.210.16D	320	1:1	200	1.6	210	6 x 6.5	24	145	2.3	8.3	29.0
	T24.210.20D	320	1:1	200	2	210	6 x 6.5	24	180	1.6	9.1	36.0

	MAX PAYLOAD	ROPING	RATED TORQUE M_N	SPEED	TRACTION SHEAVE Ø	MAX ROPES Ø	POLES	RATED SPEED n	RATED POWER	CURRENT	FREQUENCY SUPPLY	
TYPE	kg		Nm	m/s	mm	mm		min-1	kW	Amp	Hz	
Static load 20 kN												
T24L	T24L.210.10	630	2:1	250	1	210	6 x 6.5	24	180	4.7	11.1	36.0
	T24L.210.16	630	2:1	250	1.6	210	6 x 6.5	24	290	7.6	15.9	58.0
	T24L.210.20	630	2:1	250	2	210	6 x 6.5	24	360	9.5	19.9	72.0
	T24L.240.10	630	2:1	250	1	240	6 x 6.5	24	160	4.2	11.1	32.0
	T24L.240.16	630	2:1	250	1.6	240	6 x 6.5	24	255	6.7	15.9	51.0
	T24L.240.20	630	2:1	250	2	240	6 x 6.5	24	320	8.3	17.7	64.0
	T24L.240.10D	320	1:1	250	1	240	6 x 6.5	24	80	2.1	6.5	16.0
	T24L.240.16D	320	1:1	250	1.6	240	6 x 6.5	24	127	3.3	9.2	25.5
	T24L.240.20D	320	1:1	250	2	240	6 x 6.5	24	160	4.2	11.1	32.0

PERFORMANCE DATA T32S - T32 - T32L - T32XL

	MAX PAYLOAD	ROPING	RATED TORQUE M _N	SPEED	TRACTION SHEAVE Ø	MAX ROPES Ø	POLES	RATED SPEED n	RATED POWER	CURRENT	FREQUENCY SUPPLY
TYPE	kg		Nm	m/s	mm	mm		min-1	kW	Amp	Hz

Static load 26 kN

T32S	T32S.320.10	630	2:1	330	1	320	7 x 8	30	120	4.1	11.1	30.0
	T32S.320.16	630	2:1	330	1.6	320	7 x 8	30	190	6.6	16.4	47.5
	T32S.320.20	630	2:1	330	2	320	7 x 8	30	240	8.3	20.7	60.0
	T32S.320.25	630	2:1	330	2.5	320	7 x 8	30	300	10.4	23.1	75.0
	T32S.240.10	800	2:1	330	1	240	10 x 6.5	30	160	5.5	13.0	40.0
	T32S.240.16	800	2:1	330	1.6	240	10 x 6.5	30	255	8.8	20.7	63.8
	T32S.240.20	800	2:1	330	2	240	10 x 6.5	30	320	11.0	24.6	80.0
	T32S.320.10D	320	1:1	330	1	320	7 x 8	30	60	2.1	7.0	15.0
	T32S.320.16D	320	1:1	330	1.6	320	7 x 8	30	95	3.3	8.1	23.8
	T32S.320.20D	320	1:1	330	2	320	7 x 8	30	120	4.1	10.9	30.0
	T32S.320.25D	320	1:1	330	2.5	320	7 x 8	30	150	5.2	13.0	37.5
	T32S.240.10D	450	1:1	330	1	240	10 x 6.5	30	80	2.8	7.0	20.0
	T32S.240.16D	450	1:1	330	1.6	240	10 x 6.5	30	127	4.4	9.8	31.8
	T32S.240.20D	450	1:1	330	2	240	10 x 6.5	30	160	5.5	13.0	40.0

	MAX PAYLOAD	ROPING	RATED TORQUE M _N	SPEED	TRACTION SHEAVE Ø	MAX ROPES Ø	POLES	RATED SPEED n	RATED POWER	CURRENT	FREQUENCY SUPPLY
TYPE	kg		Nm	m/s	mm	mm		min-1	kW	Amp	Hz

Static load 26 kN

T32	T32.320.10	800	2:1	480	1	320	7 x 8	30	120	6.0	15.0	30.0
	T32.320.16	800	2:1	480	1.6	320	7 x 8	30	190	9.6	22.9	47.5
	T32.320.20	800	2:1	480	2	320	7 x 8	30	240	12.1	26.7	60.0
	T32.320.25	800	2:1	480	2.5	320	7 x 8	30	300	12.9	32.5	75.0
	T32.240.10	1000	2:1	480	1	240	10 x 6.5	30	160	8.0	18.1	40.0
	T32.240.16	1000	2:1	480	1.6	240	10 x 6.5	30	255	12.8	29.2	63.8
	T32.240.20	1000	2:1	480	2	240	10 x 6.5	30	320	16.1	34.9	80.0
	T32.320.10D	480	1:1	480	1	320	7 x 8	30	60	3.0	8.8	15.0
	T32.320.16D	480	1:1	480	1.6	320	7 x 8	30	95	4.8	13.6	23.8
	T32.320.20D	480	1:1	480	2	320	7 x 8	30	120	6.0	15.0	30.0
	T32.320.25D	480	1:1	480	2.5	320	7 x 8	30	150	7.5	18.1	37.5
	T32.240.10D	630	1:1	480	1	240	10 x 6.5	30	80	4.0	10.7	20.0
	T32.240.16D	630	1:1	480	1.6	240	10 x 6.5	30	127	6.4	15.0	31.8
	T32.240.20D	630	1:1	480	2	240	10 x 6.5	30	160	8.0	18.1	40.0

	MAX PAYLOAD	ROPING	RATED TORQUE M _N	SPEED	TRACTION SHEAVE Ø	MAX ROPES Ø	POLES	RATED SPEED n	RATED POWER	CURRENT	FREQUENCY SUPPLY
TYPE	kg		Nm	m/s	mm	mm		min-1	kW	Amp	Hz

Static load 32 kN

T32L	T32L.400.10	1000	2:1	660	1	400	5 x 10	30	95	6.6	15.8	23.7
	T32L.400.16	1000	2:1	660	1.6	400	5 x 10	30	155	10.7	24.5	38.75
	T32L.320.10	1250	2:1	660	1	320	7 x 8	30	120	8.3	20.5	30.0
	T32L.320.16	1250	2:1	660	1.6	320	7 x 8	30	190	13.2	31.4	47.5
	T32L.320.20	1250	2:1	660	2	320	7 x 8	30	240	16.6	37.8	60.0
	T32L.320.25	1250	2:1	660	2.5	320	7 x 8	30	300	20.7	45.7	75.0
	T32L.240.10	1275	2:1	660	1	240	10 x 6.5	30	160	11.0	25.2	40.0
	T32L.240.16	1275	2:1	660	1.6	240	10 x 6.5	30	255	17.6	37.8	63.8
	T32L.240.20	1275	2:1	660	2	240	10 x 6.5	30	320	22.1	47.9	80.0
	T32L.320.10D	600	1:1	660	1	320	7 x 8	30	60	4.1	11.9	15.0
	T32L.320.16D	600	1:1	660	1.6	320	7 x 8	30	95	6.6	17.3	23.8
	T32L.320.20D	600	1:1	660	2	320	7 x 8	30	120	8.3	20.5	30.0
	T32L.320.25D	600	1:1	660	2.5	320	7 x 8	30	150	10.3	25.2	37.5
	T32L.240.10D	800	1:1	660	1	240	10 x 6.5	30	80	5.5	15.8	20.0
	T32L.240.16D	800	1:1	660	1.6	240	10 x 6.5	30	127	8.8	19.7	31.8
	T32L.240.20D	800	1:1	660	2	240	10 x 6.5	30	160	11.0	25.2	40.0

	MAX PAYLOAD	ROPING	RATED TORQUE M _N	SPEED	TRACTION SHEAVE Ø	MAX ROPES Ø	POLES	RATED SPEED n	RATED POWER	CURRENT	FREQUENCY SUPPLY
TYPE	kg		Nm	m/s	mm	mm		min-1	kW	Amp	Hz

Static load 41 kN

T32XL	T32XL.320.10	1600	2:1	850	1	320	10 x 8	30	120	10.7	25.1	30.0
	T32XL.320.16	1600	2:1	850	1.6	320	10 x 8	30	190	17.0	35.6	47.5
	T32XL.320.20	1600	2:1	850	2	320	10 x 8	30	240	21.4	45.2	60.0
	T32XL.320.25	1600	2:1	850	2.5	320	10 x 8	30	300	26.7	55.0	75.0
	T32XL.320.10D	800	1:1	850	1	320	10 x 8	30	60	5.4	14.2	15.0
	T32XL.320.16D	800	1:1	850	1.6	320	10 x 8	30	95	8.5	20.3	23.8
	T32XL.320.20D	800	1:1	850	2	320	10 x 8	30	120	10.7	25.1	30.0
	T32XL.320.25D	800	1:1	850	2.5	320	10 x 8	30	150	13.4	30.1	37.5

DIMENSIONS M24S/T24S - M24/T24 -T24L - T32S - T32 - T32L - T32XL

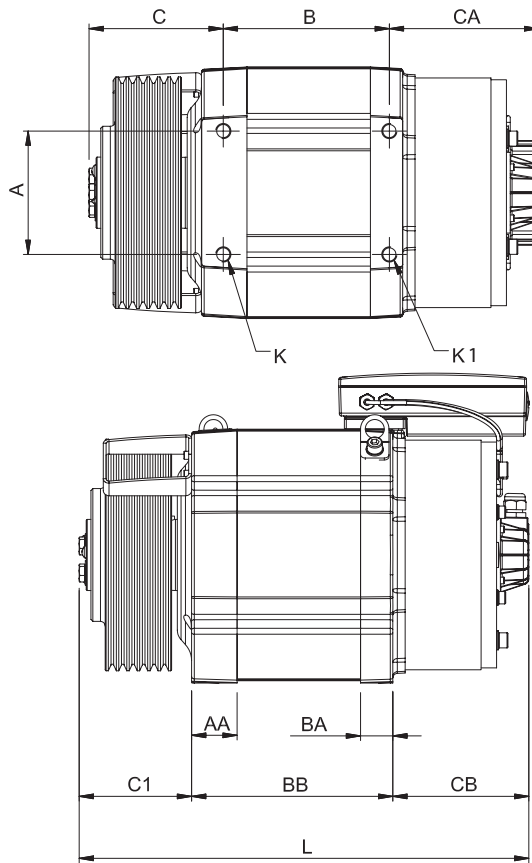

TYPE	K	K1
M24S/T24S	M16x2∇25	M16x2∇25
M24/T24	M16x2∇25	M16x2∇25
T24L	M16x2∇25	M16x2∇25
<hr/>		
T32S	M20x2.5∇40	M20x2.5∇25
T32	M20x2.5∇40	M20x2.5∇25
T32L	M20x2.5∇40	M20x2.5∇25
T32XL	M20x2.5∇40	M20x2.5∇40

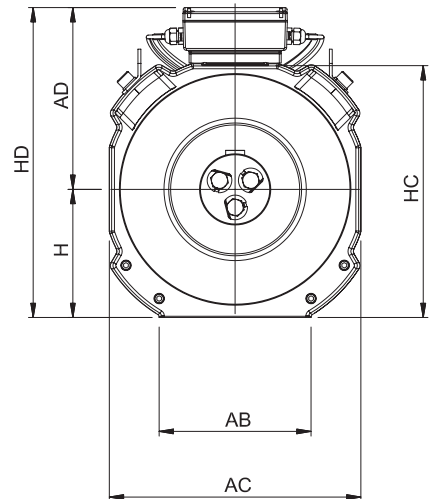

TYPE	A	B	C	C1	CA	CB	BB	AA	BA	L	AC	AB	HD	H	AD	HC	WEIGHT kg
M24S/T24S.160.XX	130	175	141	118	157	143	212	48	34	474	265	160	327	135	192	268	127
M24S/T24S.210.XX	130	175	141	118	157	143	212	48	34	474	265	160	327	135	192	268	127
M24S/T24S.240.XX	130	175	141	118	157	143	212	48	34	474	265	160	327	135	192	268	132
<hr/>																	
M24/T24.160.XX	130	215	141	118	157	143	252	48	34	514	265	160	327	135	192	268	135
M24/T24.210.XX	130	215	141	118	157	143	252	48	34	514	265	160	327	135	192	268	135
M24/T24.240.XX	130	215	141	118	157	143	252	48	34	514	265	160	327	135	192	268	140
T24.210.XX.D	130	215	141	118	157	143	252	48	34	514	265	160	327	135	192	268	140
<hr/>																	
T24L.210.XX	130	255	158	135	157	143	292	48	34	570	265	160	327	135	192	268	153
T24L.240.XX	130	255	158	135	157	143	292	48	34	570	265	160	327	135	192	268	158
T24L.210.XX.D	130	255	158	135	157	143	292	48	34	570	265	160	327	135	192	268	153
T24L.240.XX.D	130	255	158	135	157	143	292	48	34	570	265	160	327	135	192	268	158
<hr/>																	
T32S.240.XX	170	175	175	157	155	135	213	58	60	505	348	208	396	175	221	350	189
T32S.320.XX	170	175	159	140	155	135	213	58	60	488	348	208	396	175	221	350	184
T32S.240.XX.D	170	175	175	157	155	135	213	58	60	505	348	208	396	175	221	350	189
T32S.320.XX.D	170	175	159	140	155	135	213	58	60	488	348	208	396	175	221	350	184
<hr/>																	
T32.240.XX	170	215	175	157	155	135	253	58	60	545	348	208	396	175	221	350	215
T32.320.XX	170	215	159	140	155	135	253	58	60	528	348	208	396	175	221	350	210
T32.240.XX.D	170	215	175	157	155	135	253	58	60	545	348	208	396	175	221	350	215
T32.320.XX.D	170	215	159	140	155	135	253	58	60	528	348	208	396	175	221	350	210
<hr/>																	
T32L.240.XX	170	260	175	157	162	142	298	58	60	597	348	208	396	175	221	350	264
T32L.320.XX	170	260	159	140	162	142	298	58	60	580	348	208	396	175	221	350	259
T32L.400.XX	170	260	159	140	162	142	298	58	60	580	348	208	396	175	221	350	268
T32L.240.XX.D	170	260	175	157	162	142	298	58	60	597	348	208	396	175	221	350	264
T32L.320.XX.D	170	260	159	140	162	142	298	58	60	580	348	208	396	175	221	350	259
<hr/>																	
T32XL.320.XX	170	326	196	172	203	173	380	77	73	725	352	209	425	180	245	355	380
T32XL.320.XX.D	170	326	196	172	203	173	380	77	73	725	352	209	425	180	245	355	380

ORDER DATA

Drive supply	<input type="checkbox"/> Single-phase 230V	<input type="checkbox"/> Three-phase 400V
Max payload	<input type="checkbox"/> 240 kg <input type="checkbox"/> 320 kg <input type="checkbox"/> 450 kg <input type="checkbox"/> 480 kg <input type="checkbox"/> 600 kg <input type="checkbox"/> 630 kg	<input type="checkbox"/> 800 kg <input type="checkbox"/> 1000 kg <input type="checkbox"/> 1250 kg <input type="checkbox"/> 1275 kg <input type="checkbox"/> 1600 KG <input type="checkbox"/> other ____ kg
Traction sheave Ø external	<input type="checkbox"/> 160 mm <input type="checkbox"/> 210 mm <input type="checkbox"/> 240 mm	<input type="checkbox"/> 320 mm <input type="checkbox"/> 400 mm <input type="checkbox"/> other ____mm
Ropes no.	<input type="checkbox"/> 4 <input type="checkbox"/> 5 <input type="checkbox"/> 6 <input type="checkbox"/> other ____	<input type="checkbox"/> 7 <input type="checkbox"/> 8 <input type="checkbox"/> 10
Ropes Ø	<input type="checkbox"/> 6.5 mm <input type="checkbox"/> 8 mm	<input type="checkbox"/> other ____mm
Traction sheave groove profile	<input type="checkbox"/> $V \gamma = 50^\circ$ <input type="checkbox"/> $V \gamma = _____\circ$ <input type="checkbox"/> semi-circular with notch $\gamma = 30^\circ \beta = 100^\circ$ <input type="checkbox"/> semi-circular with notch $\gamma = __\circ \beta = __\circ$ <input type="checkbox"/> other ____	
Roping	<input type="checkbox"/> 2:1	<input type="checkbox"/> 1:1
Plant speed	<input type="checkbox"/> 0.5 m/s <input type="checkbox"/> 0.6 m/s <input type="checkbox"/> 1.0 m/s <input type="checkbox"/> other ____m/s	<input type="checkbox"/> 1.6 m/s <input type="checkbox"/> 2.0 m/s <input type="checkbox"/> 2.5 m/s
Encoder type (as standard: absolute sin-cos 1Vpp 2048p/t 5V)	<input type="checkbox"/> incremental TTL 4096p/t 5V <input type="checkbox"/> incremental HTL 4096p/t 10...30V <input type="checkbox"/> absolute EnDat 2.1 13bit 2048p/t 3.6...14V	
Requested options	<input type="checkbox"/> brake hand release (check max. NE distance available ____ mm) <input type="checkbox"/> other ____	

Needed data for the complete definition of the gearless machine for elevators, to be filled in by customer.

STANDARDS AND REGULATIONS





Lafert Servo Motors S.p.A.

E. Majorana, 2/a
I-30020 Noventa di Piave (Venezia), Italy
Tel. +39 / 0421 572 211
Fax +39 / 0421 225 858
lsm.info@shi-g.com

Lafert S.p.A.

Via J.F. Kennedy,43
I-30027 San Donà di Piave (Venice), Italy
Tel. +39 / 0421 229 611
Fax +39 / 0421 222 908
lafert.info@shi-g.com

www.lafert.com

Branches & Partners

Lafert GmbH

Wolf-Hirth-Straße 10
D-71034 Böblingen
Germany
Phone +49 175 550 4526
lge.info@shi-g.com

Lafert Electric Motors Ltd.

Unit 17 Orion Way
Crewe, Cheshire CW1 6NG
United Kingdom
Phone +44 / (0) 1270 270 022
luk.info@shi-g.com

Lafert Moteurs S.A.S.

L'Isle d'Abeau Parc de Chesnes
75, rue de Malacombe
F - 38070 St. Quentin-Fallavier
France
Phone +33 / 474 95 41 01
lfr.info@shi-g.com

Lafert Motores Electricos, S.L.U.

Poligono Pignatelli, Nave 27
E - 50410 Cuarte de Huerva (Zaragoza)
Spain
Phone +34 / 976 503 822
les.info@shi-g.com

Lafert N.A. (North America)

5620 Kennedy Road - Mississauga
Ontario L4Z 2A9
Canada
Phone +1 / 800/661 6413 - 905/629 1939
lna.info@shi-g.com

Lafert Electric Motors (Australia)

Factory 3, 117-123 Abbott Road,
Hallam - VIC 3803
Australia
Phone +61 / (0)3 95 46 75 15
info@lafertaust.com.au

Lafert Singapore Pte Ltd

48 Hillview Terrace #06-06
Hillview Building - Singapore 669269
Phone +65 / 67630400 - 67620400
info@lafert.com.sg

Lafert (Suzhou) Co., Ltd.

No.3 Industrial Plant Building Yue Xi Phase 3,
Tian E Dang Lu 2011, 215104 Wuzong
Economic Development Zone, Suzhou
China
Phone +86 / 512 6687 0618
lsu.info@shi-g.com