

PAD MOUNTING SERIES

AXIAL FANS APPLICATIONS

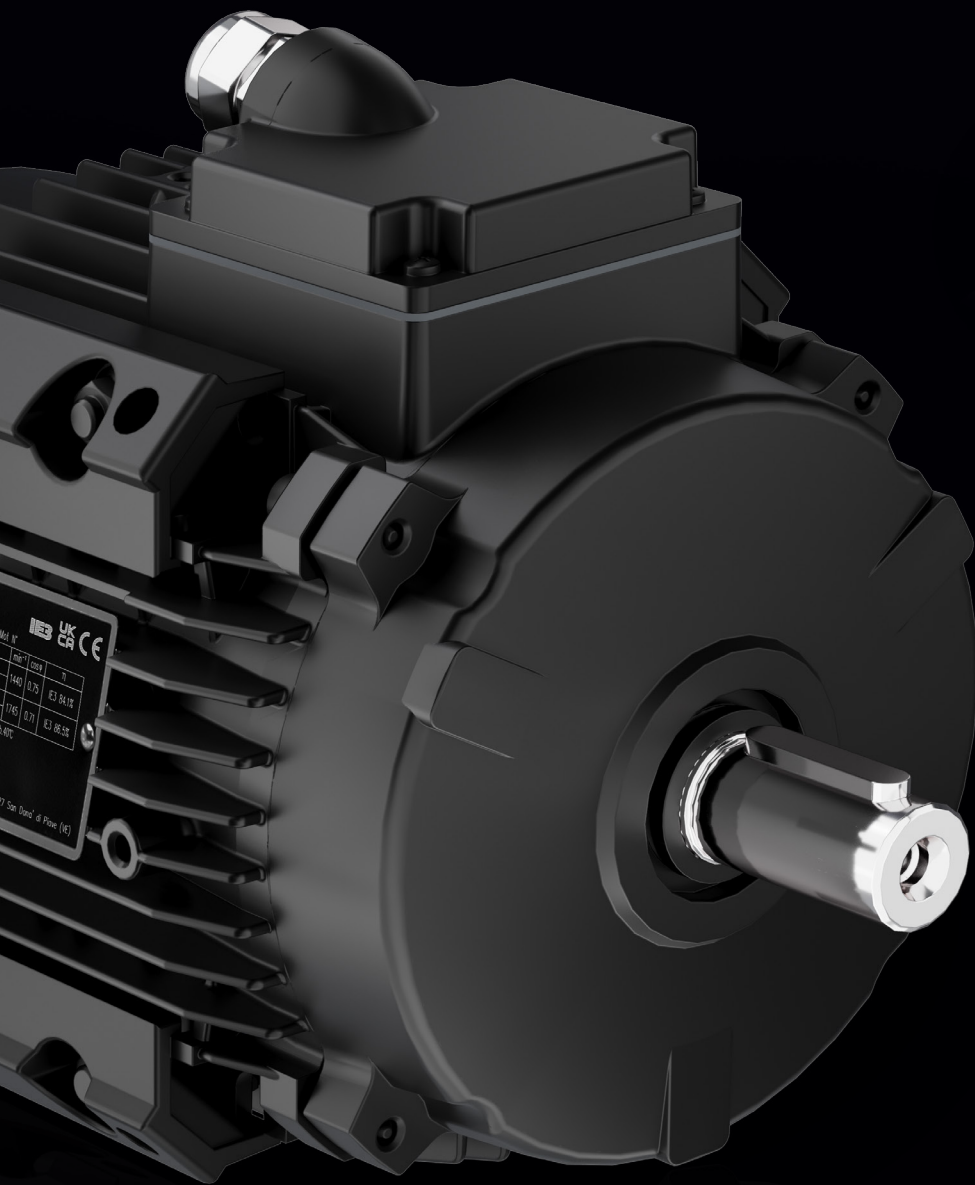

WATER SLINGER

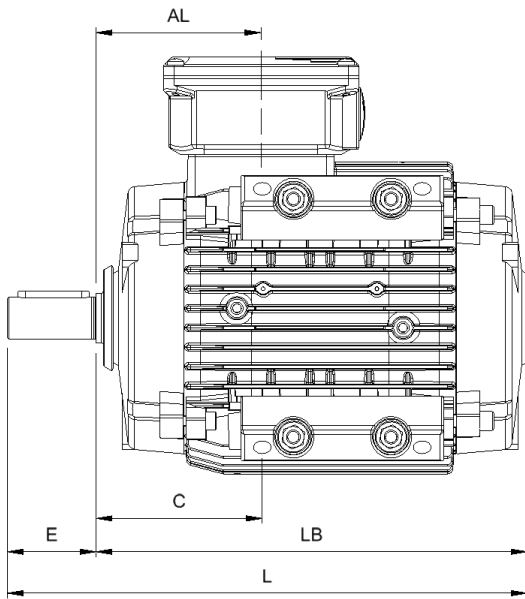

TYPE	C	L	LB	AL	E
80	62	244	204	85	40
90S-L	68.5	292.5	242.5	92.5	50
90XL	68.5	312.5	262.5	92.5	50
100L	88.5	329.5	269.5	97.5	60
112M	100	348	288	102	60
112XL	100	371	311	102	60
132S	89	385	305	101	80
132M	109	425	345	121	80
132XL	109	455	375	121	80
132XXL	109	500	420	121	80
160M	118	535	425	151	110
160L	140	579	469	173	110

FLAT LID

Thanks to the **flat lid**, our new ultra-compact terminal box design, the overall footprint of the motor is further reduced as well as airflow obstruction.

The flat lid is available upon request, please contact us for further clarification.

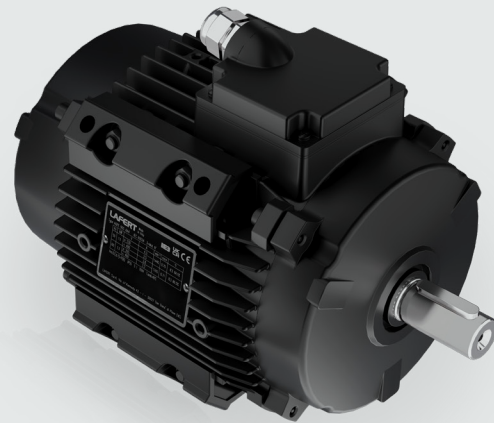

PRODUCT STRENGTHS

- ADAPTABILITY**
If a thread strips, the motor isn't scrap, just replace the pad!
- FLEXIBILITY**
The pads are designed to fit our standard housings so by default the Lafert menu of options is open.
- RELIABILITY**
All pads have been stringently tested and optimized to meet demanding pull tests.



CUSTOMIZATION AT ALL LEVELS

The quality of Lafert motors is generated by the constant search for innovative solutions and by our natural propensity for customization and co-engineering. Lafert specializes in designing and manufacturing customized electric motors and drives, created to meet the needs of each customer. **More than 90% of Lafert products are non-standard motors.**

Thanks to our strong approach to the market, the experience in special applications and the wide range of solutions, we can offer the electric and mechanical design perfect for every application need. The co-designing approach from our engineers and the skillful expertise of our technical office to adapt the

motor to specific market segments allow us to offer an exceptionally high level of customization, efficiency, and reliability.

To ensure the maximum performance of our motors we produce every component internally. This allows us to tailor every element of our proposals by developing **infinite solutions for all applications.**

From flange design to special windings, from the degree of protection to the fan cooling, we customize everything to create the perfect motor that maximizes the performance and energy savings of the final application.

PAD MOUNTING SERIES

The pad mounting series stems from the desire to meet the application needs of axial fans where the mounting of motors with reduced dimensions and without protruding elements allows to minimize the impact on the air flow thus ensuring a reduction in energy consumption. The pad mounting design, in fact, uses four special feet that are located at 90 ° on the motor body minimizing the impact on the air flow, making the system more efficient.

We have developed a series of removable pads to fix to our existing multi-mount design covering all sizes and motor types from 80 to 160. We can therefore offer with pad mounting design both asynchronous motors in efficiency class IE1, IE2, IE3 and IE4 and synchronous permanent magnet motors with IE4 and IE5 efficiency, with considerable advantage for the customer who can without any redesign of his machine switch to a solution with higher aerodynamic efficiency and meet the latest European Ecodesign Directive/ErP requirements.

TARGET APPLICATIONS

HVAC	MAIN FEATURES	SPECIALITIES
<p>AXIAL FANS FOR INDUSTRIAL AND COMMERCIAL ENVIRONMENT</p>	<ul style="list-style-type: none"> • IEC range – 80 to 160 frame size • Asynchronous and synchronous PM design • Replaceable pad mounting design IM B30 • Without ventilation (IC418 – TEAO design) 	<ul style="list-style-type: none"> • High corrosion protection level (according to ISO 12944) • Special insulation system/voltage/frequency • Wide ambient temperature range • Flat lid • Water slinger

ULTRA PREMIUM EFFICIENCY PM MOTORS – IE5

EFFICIENCY LEVEL ACCORDING TO IEC TS 60034-30-2:2016

FOR MAINS VOLTAGE
400 V - 50 HZ

IE5

TEMPERATURE RISE TO CLASS B

Type	Size	n rpm	P _n kW	M _N Nm	M _{pk} Nm	K _e Vs	K _t Nm/A	E _n Vrs	I _n Arms	η [*] %	kg
1500 rpm											
HPS90 1500 32	S-L	1500	1.5	9.6	28.7	1.73	3	272	3.2	89.1	14
HPS90 1500 47	S-L	1500	2.2	14.0	42.0	1.73	3	272	4.7	90.2	14
HPS90 1500 64	XL	1500	3	19.1	57.3	1.73	3	272	6.4	91.0	18
HPS90 1500 85	XL	1500	4	25.5	76.4	1.73	3	272	8.5	91.8	19
HPS112 1500 85	M	1500	4	25.5	76.4	1.73	3	272	8.5	91.8	26
HPS112 1500 117	M	1500	5.5	35.0	105.1	1.73	3	272	11.7	92.5	30
HPS112 1500 159	XL	1500	7.5	47.8	143.3	1.73	3	272	15.9	93.2	33
HPS112 1500 195	XL	1500	9.2	58.6	175.8	1.73	3	272	19.5	93.5	33
HPS132 1500 233	XL	1500	11	70.0	210.1	1.73	3	272	23.3	93.8	56
HPS132 1500 318	XXL	1500	15	95.5	286.5	1.73	3	272	31.8	94.4	65
HPS132 1500 393	XXL	1500	18.5	117.8	353.4	1.73	3	272	39.3	94.6	65
HPS160 1500 233	M	1500	11	70	175	1.73	3	272	23.3	93.8	70
HPS160 1500 318	M	1500	15	95	239	1.73	3	272	31.8	94.4	75
HPS160 1500 393	M	1500	18.5	118	294	1.73	3	272	39.3	94.6	85
HPS160 1500 467	L	1500	22	140	350	1.73	3	272	46.7	94.9	95
HPS160 1500 637	L	1500	30	191	477	1.73	3	272	63.7	95.3	115
3000 rpm											
HPS90 3000 47	S-L	3000	2.2	7.0	21.0	0.87	1.5	272	4.7	88.9	10
HPS90 3000 64	S-L	3000	3	9.6	28.7	0.87	1.5	272	6.4	89.9	12
HPS90 3000 85	S-L	3000	4	12.7	38.2	0.87	1.5	272	8.5	90.7	14
HPS90 3000 117	S-L	3000	5.5	17.5	52.5	0.87	1.5	272	11.7	91.6	16
HPS112 3000 117	M	3000	5.5	17.5	52.5	0.87	1.5	272	11.7	91.6	23
HPS112 3000 159	M	3000	7.5	23.9	71.6	0.87	1.5	272	15.9	92.4	26
HPS112 3000 233	M	3000	11	35.0	105.1	0.87	1.5	272	23.3	93.2	30
HPS112 3000 318	M	3000	15	47.8	143.3	0.87	1.5	272	31.8	93.7	33
HPS132 3000 318	M	3000	15	47.8	143.3	0.87	1.5	272	31.8	93.7	55
HPS132 3000 393	XL	3000	18.5	58.9	176.7	0.87	1.5	272	39.3	94.2	59
HPS132 3000 467	XXL	3000	22	70.0	210.1	0.87	1.5	272	46.7	94.4	67
HPS132 3000 636	XXL	3000	30	95.4	286.0	0.87	1.5	272	63.6	94.9	72
HPS160 3000 634	L	3000	30	95.4	239	0.87	1.51	272	63.4	94.9	90
HPS160 3000 782	L	3000	37	118.0	294	0.87	1.51	272	78.2	95.2	95

* In new IEC TS 60034-30-2, the IE class limit values are reduced by adding the additional harmonic losses caused by the drive: 15% additional losses for motors up to 90 kW



SUPER PREMIUM EFFICIENCY THREE-PHASE MOTORS – IE4

EFFICIENCY LEVEL ACCORDING TO IEC 60034-30-1;2014 | EFFICIENCY TESTING METHOD IEC 60034-2-1;2014
NOMINAL FULL LOAD EFFICIENCY ACCORDING TO IE4 CODE @ 400 V - 50 HZ

FOR MAINS VOLTAGE
400 V - 50 HZ

IE4

TEMPERATURE RISE TO CLASS B

Type	kW	HP	n rpm	M _N Nm	η			cos φ	I _N 400V	I _A /I _N	M _A /M _N	M _S /M _N	M _K /M _N	J 10 ⁻³ kgm ²	kg	
					50%	75%	100%									
3000 rpm (2 poles)																
AGQE 80Z AA	2	0.75	1	2895	2.5	81.6	84.3	83.5	0.79	1.7	8.1	5.1	4.4	5.4	0.7	9.5
AGQE 80Z BA	2	1.1	1.5	2865	3.7	83.8	85.8	85.2	0.76	2.4	8.5	4.9	4.5	4.6	0.9	11.1
AGQE 90S AA	2	1.5	2	2910	4.9	85.6	87.2	86.5	0.81	3.1	9.0	4.8	4.2	5.1	1.6	16.4
AGQE 90L BA	2	2.2	3	2915	7.3	87.7	89.0	88.0	0.79	4.3	9.8	5.0	4.7	5.4	2.0	18.0
AGQE 112M XA	2	3	4	2920	9.8	88.8	89.9	89.1	0.91	5.3	15.8	5.1	4.2	5.6	8.6	33.6
AGQE 112M AA	2	4	5.5	2950	13.0	87.9	89.7	90.0	0.83	7.8	16.0	5.3	4.2	5.7	8.6	33.6
AGQE 132S AA	2	5.5	7.5	2955	17.8	86.4	89.5	90.9	0.87	10.1	14.4	5.3	4.5	6.8	17.5	58.0
AGQE 132S BA	2	7.5	10	2959	24.3	87.8	90.3	91.7	0.82	14.5	12.3	4.1	2.3	5.3	25.0	59.0
AGQE 132M CA	2	9.2	12.4	2953	29.9	90.5	91.4	91.8	0.84	16.6	12.8	4.3	3.7	4.8	28.0	68.0
AGQE 160M AA	2	9.2	12.4	2970	29.9	88.3	91.0	92.2	0.85	16.9	14.0	5.0	4.3	5.2	53.4	88.9
AGQE 160M BA	2	11	15	2965	35.6	89.5	91.7	92.6	0.84	20.3	13.8	5.1	4.5	5.3	53.4	88.9
AGQE 160M CA	2	15	20	2965	48.7	89.8	92.0	93.3	0.84	27.8	12.4	5.1	4.5	5.5	64.0	104.0
1500 rpm (4 poles)																
AGQE 90S AA4	4	0.75	1	1445	5.0	83.0	85.0	85.7	0.76	1.7	8.4	4.7	2.8	4.3	3.7	16.4
AGQE 90L BA4	4	1.1	1.5	1450	7.3	84.1	86.3	86.7	0.72	2.5	8.6	4.3	3.3	4.7	3.9	20.0
AGQE 100L AA4	4	1.1	1.5	1473	7.2	85.2	87.8	87.2	0.74	2.5	9.7	4.3	3.3	4.7	8.9	21.5
AGQE 100L BA4	4	1.5	2	1470	9.8	86.4	88.4	88.2	0.77	3.2	10.7	4.1	3.1	4.6	10.7	25.3
AGQE 100L CA4	4	2.2	3	1472	14.3	87.3	89.2	89.5	0.78	4.6	10.1	4.1	3.5	4.5	14.9	29.0
AGQE 112M BA4	4	3	4	1464	19.7	88.8	90.1	90.4	0.79	6.1	9.0	3.6	2.3	4.2	17.4	38.9
AGQE 132S AA4	4	4	5.5	1477	25.9	89.0	90.7	91.1	0.79	8.1	10.2	4.6	3.9	4.4	33.0	49.0
AGQE 132S BA4	4	5.5	7.5	1476	35.7	90.3	91.7	91.9	0.80	10.8	10.2	3.5	2.8	4.3	45.0	62.0
AGQE 132M CA4	4	7.5	10	1472	49.1	90.8	92.3	92.6	0.81	14.5	8.7	2.9	2.1	3.4	57.0	71.0
AGQE 160M AA4	4	9.2	12.4	1482	59.8	92.3	93.6	93.0	0.80	17.9	8.6	2.7	2.0	3.5	105.0	105.0
AGQE 160M BA4	4	11	15	1482	71.3	91.7	93.0	93.3	0.80	21.4	9.1	2.5	2.0	3.2	120.7	110.0
AGQE 160L CA4	4	15	20	1480	97.4	91.8	93.3	93.9	0.80	29.0	8.1	1.9	1.3	3.0	135.0	125.0
1000 rpm (6 poles)																
AGQE 100L AA	6	0.75	1	970	7.5	82.5	84.6	82.7	0.66	2.0	5.5	2.3	2.3	2.8	9.7	23.0
AGQE 100L BA	6	1.1	1.5	966	10.9	83.1	84.9	84.5	0.65	2.9	5.2	2.4	2.0	2.8	10.7	25.0
AGQE 100L CA	6	1.5	2	967	14.9	85.3	86.6	85.9	0.70	3.6	5.9	2.6	1.9	2.8	13.3	28.0
AGQE 112M AA	6	2.2	3	968	21.8	86.7	87.9	87.4	0.68	5.3	6.7	2.3	1.8	3.0	23.1	36.5
AGQE 132S AA	6	3	4	975	29.6	87.5	89.0	88.6	0.70	7.0	6.5	3.0	2.0	2.7	44.4	46.0
AGQE 132M BA	6	4	5.5	976	39.4	87.6	89.2	89.5	0.68	9.5	6.2	2.0	1.7	2.5	54.1	48.0
AGQE 160M AA	6	5.5	7.5	981	53.6	88.2	90.2	90.5	0.78	10.3	7.9	1.7	1.0	3.1	130.0	105.0
AGQE 160L BA	6	7.5	10	981	73.8	89.1	91.2	91.3	0.73	16.3	10.4	2.1	3.1	3.5	136.0	115.0



PREMIUM EFFICIENCY THREE-PHASE MOTORS – IE3

EFFICIENCY LEVEL ACCORDING TO IEC 60034-30-1;2014 | EFFICIENCY TESTING METHOD IEC 60034-2-1;2014
NOMINAL FULL LOAD EFFICIENCY ACCORDING TO IE3 CODE @ 400 V - 50 HZ

FOR MAINS VOLTAGE
400 V - 50 HZ

IE3

TEMPERATURE RISE TO CLASS B

Type	kW	HP	n rpm	M _N Nm	η			cos φ	I _N 400V	I _x /I _N	M _x /M _N	M _s /M _N	M _k /M _N	J		
					50%	75%	100%							10 ⁻³ kgm ²	kg	
3000 rpm (2 poles)																
AGPE 80Z AA	2	0.75	1	2910	2.5	77.8	81.2	82.0	0.78	1.7	8.9	4.7	4.5	4.8	0.7	9.5
AGPE 80Z BA	2	1.1	1.5	2870	3.7	78.7	81.7	82.7	0.76	2.4	9.3	5.0	4.9	5.3	0.9	11.1
AGPE 80Z CA	2*	1.5	2	2810	5.1	78.8	82.2	84.2	0.76	3.6	7.8	4.9	3.7	4.3	1.1	13.5
AGPE 90S AA	2	1.5	2	2875	5.0	83.2	84.8	84.2	0.85	3.0	8.4	3.6	3.2	3.8	1.56	14.0
AGPE 90L BA	2	2.2	3	2880	7.3	85.0	86.2	86.5	0.82	4.6	9.2	4.0	3.8	4.2	1.8	16.0
AGPE 90L DA	2*	3	4	2865	10.0	85.2	86.3	87.1	0.80	6.3	8.7	4.5	4.0	4.6	2.0	18.0
AGPE 112M XA	2	3	4	2940	10.0	85.2	86.3	87.1	0.89	5.5	10.0	3.8	3.2	4.2	6.48	27.4
AGPE 112M AA	2	4	5.5	2910	13.1	86.8	87.8	88.1	0.93	7.0	9.6	3.6	3.0	4.0	6.48	27.4
AGPE 112M BA	2*	5.5	7.5	2935	17.9	85.6	88.3	89.2	0.87	10.2	11.2	4.2	3.5	4.3	8.6	33.6
AGPE 112M CA	2*	7.5	10	2930	24.5	88.0	89.7	90.1	0.84	14.4	10.4	4.5	3.5	4.6	10.5	36.0
AGPE 132S ZA	2	5.5	7.5	2920	18.0	88.0	88.5	89.2	0.90	10.0	8.9	3.0	2.5	3.6	14.0	46.0
AGPE 132S TA	2	7.5	10	2910	24.6	88.6	89.2	90.1	0.92	13.1	8.9	3.0	2.6	3.6	16.0	53.0
AGPE 132M ZA	2	9.2	12.4	2930	30.0	88.6	89.8	90.7	0.89	16.5	10.1	3.7	3.3	4.0	17.5	58.0
AGPE 132M RA	2*	11	15	2935	35.8	90.0	90.8	91.2	0.89	19.9	9.7	4.4	3.5	4.6	25.0	59.0
AGPE 132M TA	2*	15	20	2915	49.2	91.0	92.2	91.9	0.88	26.8	9.6	3.7	2.6	3.8	28.0	68.0
AGPE 160M YA	2	11	15	2950	35.6	87.4	89.8	91.2	0.89	19.7	9.1	4.0	3.0	4.2	51.7	87.8
AGPE 160M ZA	2	15	20	2940	48.7	91.0	91.3	91.9	0.89	26.7	9.7	4.7	3.5	4.8	53.4	88.9
AGPE 160L ZA	2	18.5	25	2950	59.9	91.6	92.8	92.4	0.88	33.0	10.7	4.6	3.1	4.7	64.0	104.0
AGPE 160L TA	2*	22	30	2950	71.3	92.2	93.7	92.7	0.87	39.4	10.4	4.5	3.0	4.6	64.0	104.0
1500 rpm (4 poles)																
AGPE 80Z XA	4	0.55	0.75	1440	3.8	75.6	80.7	80.8	0.75	1.3	6.0	2.8	2.5	2.6	1.4	8.2
AGPE 80Z AA	4	0.75	1	1435	5.0	80.7	81.5	82.5	0.74	1.8	5.5	2.7	2.6	2.8	2.5	11.0
AGPE 90S AA	4	1.1	1.5	1440	7.3	83.3	84.3	84.1	0.75	2.5	7.1	4.3	3.4	4.4	3.6	15.8
AGPE 90L BA	4	1.5	2	1430	10.0	84.1	85.2	85.3	0.72	3.6	6.6	4.3	3.8	4.4	3.7	16.4
AGPE 90L CA	4	1.8	2.4	1430	12.0	83.5	86.1	86.0	0.69	4.5	8.5	4.3	3.7	4.4	3.9	20.0
AGPE 100L AA	4	2.2	3	1455	14.4	83.2	86.2	86.7	0.63	5.9	7.2	3.7	3.0	3.9	5.9	22.8
AGPE 100L BA	4	3	4	1440	19.9	85.1	87.1	87.7	0.73	6.8	8.1	4.1	3.8	4.1	7.3	26.5
AGPE 112M BA	4	4	5.5	1450	26.4	87.2	88.3	88.6	0.80	8.2	8.5	2.7	2.4	3.5	16.4	36.0
AGPE 132S AA	4	5.5	7.5	1460	35.9	90.6	91.3	89.6	0.84	10.6	8.6	2.5	2.1	3.5	33.0	49.0
AGPE 132M BA	4	7.5	10	1465	48.9	90.8	91.5	90.4	0.84	14.2	8.6	2.5	2.1	3.5	36.0	54.0
AGPE 132M CA	4	9.2	12.4	1460	60.1	91.0	91.6	91.0	0.84	17.3	8.7	2.4	2.0	3.6	45.0	62.0
AGPE 132M DA	4*	11	15	1470	71.1	90.6	91.5	91.4	0.80	21.8	8.7	2.4	2.0	3.6	57.0	71.0
AGPE 160M AA	4	11	15	1475	71.3	91.6	92.4	91.4	0.83	21.0	8.2	2.1	1.7	2.8	89.0	100.0
AGPE 160L BA	4	15	20	1465	97.8	92.2	92.7	92.1	0.83	28.5	7.8	2.3	2.0	3.1	105.0	105.0
AGPE 160L CA	4*	18.5	25	1470	122	92.0	92.8	92.6	0.78	37.0	7.1	2.1	1.9	2.6	120.7	110.0
AGPE 160L DA	4*	22	30	1470	143.9	92.4	93.1	93.0	0.81	41.0	8.0	2.2	1.9	3.0	128.1	115.0
1000 rpm (6 poles)																
AGPE 80Z AA	6	0.37	0.5	940	3.8	70.9	72.1	73.5	0.72	1.0	2.7	1.6	1.6	2.1	1.8	8.0
AGPE 90S XA	6	0.55	0.75	940	5.6	73.4	77.2	77.2	0.67	1.5	4.5	1.6	1.5	1.8	4.8	15.0
AGPE 90S AA	6	0.75	1	940	7.6	78.1	79.2	78.9	0.62	2.2	4.6	1.7	1.6	1.8	6.0	18.1
AGPE 90L BA	6*	1.1	1.5	935	11.2	79.1	81.2	81.0	0.64	3.1	4.2	1.8	1.7	2.3	6.5	19.0
AGPE 100L AA	6	1.1	1.5	965	10.9	78.9	81.3	81.0	0.70	2.7	6.2	2.2	1.8	2.8	8.9	21.5
AGPE 100L BA	6	1.5	2	965	15.6	78.5	83.0	82.5	0.64	4.4	5.7	1.7	1.3	2.3	10.7	25.0
AGPE 112M BA	6	2.2	3	920	22.8	83.3	85.1	84.3	0.68	5.4	5.3	2.0	1.8	2.4	20.1	34.2
AGPE 132S YA	6	3	4	975	29.4	84.1	85.8	85.6	0.65	8.0	5.5	2.1	1.9	3.1	37.7	42.0
AGPE 132M YA	6	4	5.5	975	39.2	85.2	87.1	86.8	0.70	9.6	5.4	2.2	1.7	3.2	44.4	46.0
AGPE 132M TA	6*	5.5	7.5	975	53.9	87.1	88.1	88.0	0.64	14.2	5.4	2.1	1.8	2.9	54.1	48.0
AGPE 160M YA	6	5.5	7.5	975	53.9	87.5	88.5	88.0	0.77	11.8	8.6	2.2	1.8	2.8	103.0	84.0
AGPE 160LM ZA	6	7.5	10	980	73.1	88.3	89.3	89.1	0.78	15.7	8.7	2.4	1.9	3.1	132.0	97.0
AGPE 160L ZA	6	9.2	12.4	970	87.6	88.9	90.1	89.8	0.74	19.9	8.3	3.1	2.2	3.5	136.0	105.0
AGPE 160L TA	6	11	15	970	108.3	89.1	90.4	90.3	0.78	22.9	8.0	2.7	2.4	3.2	136.0	105.0

* Higher output (Progressive motor)

MECHANICAL DATA

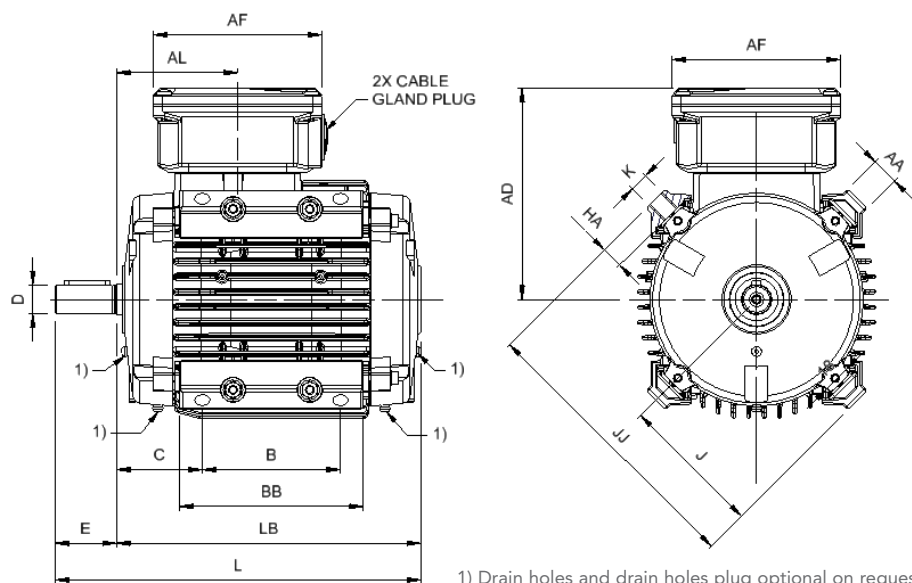
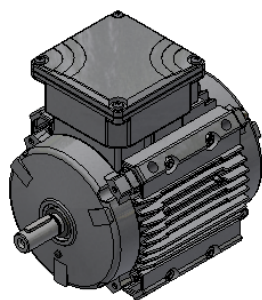

1) Drain holes and drain holes plug optional on request.

HPS RANGE – IE5

TYPE	kW	J	JJ	K	HA	AA	B	BB	C	L	LB	AF	AD	AL	D	E
90S-L	all	103	206	M12	13	24	90	114	61	285	235	110	147	85	24	50
90XL	all	103	206	M12	13	24	90	114	61	305	255	110	147	85	24	50
112M	all	125	250	M12	18	24	100	124	90	338	278	110	170	92	28	60
112XL	all	125	250	M12	18	24	100	124	90	361	301	110	170	92	28	60
132M	all	150	300	M16	20	35	140	175	109	425	345	137	196	121	38	80
132XL	all	150	300	M16	20	35	140	175	109	455	375	137	196	121	38	80
132XXL	all	150	300	M16	20	35	140	175	109	500	420	137	196	121	38	80
160M	all	180	360	M20	24	38	200	240	113	530	420	150	238	146	42	110
160L	all	180	360	M20	24	38	200	240	135	574	464	150	238	168	42	110

AGPE, AGQE RANGE – IE3, IE4

TYPE	Poles	kW	J	JJ	K	HA	AA	B	BB	C	L	LB	AF	AD	AL	D	E
80	2-4-6	all	93	186	M12	14	18	90	120	56	238	198	110	138	79	19	40
90S-L	2-4-6	all	103	206	M12	13	24	90	114	61	285	235	110	147	85	24	50
90XL	2 4	3 1.8	103	206	M12	13	24	90	114	61	305	255	110	147	85	24	50
100L	4-6	all	112.5	225	M12	15	24	100	124	83	324	264	118	154	92	28	60
112M	2-4-6	all	125	250	M12	18	24	100	124	90	338	278	110	170	92	28	60
112XL	2	7.5	125	250	M12	18	24	100	124	90	361	301	110	170	92	28	60
132S	2-4-6	all	150	300	M16	20	35	140	175	89	385	305	137	196	101	38	80
132M	4 6	7.5 4	150	300	M16	20	35	140	175	109	425	345	137	196	121	38	80
132XL	2 4 6	7.5 - 9.2 9.2 5.5	150	300	M16	20	35	140	175	109	455	375	137	196	121	38	80
132XXL	2 4	15 11	150	300	M16	20	35	140	175	109	500	420	137	196	121	38	80
160M	2-4-6	all	180	360	M20	24	38	200	240	113	530	420	150	238	146	42	110
160L	2-4-6	all	180	360	M20	24	38	200	240	135	574	464	150	238	168	42	110

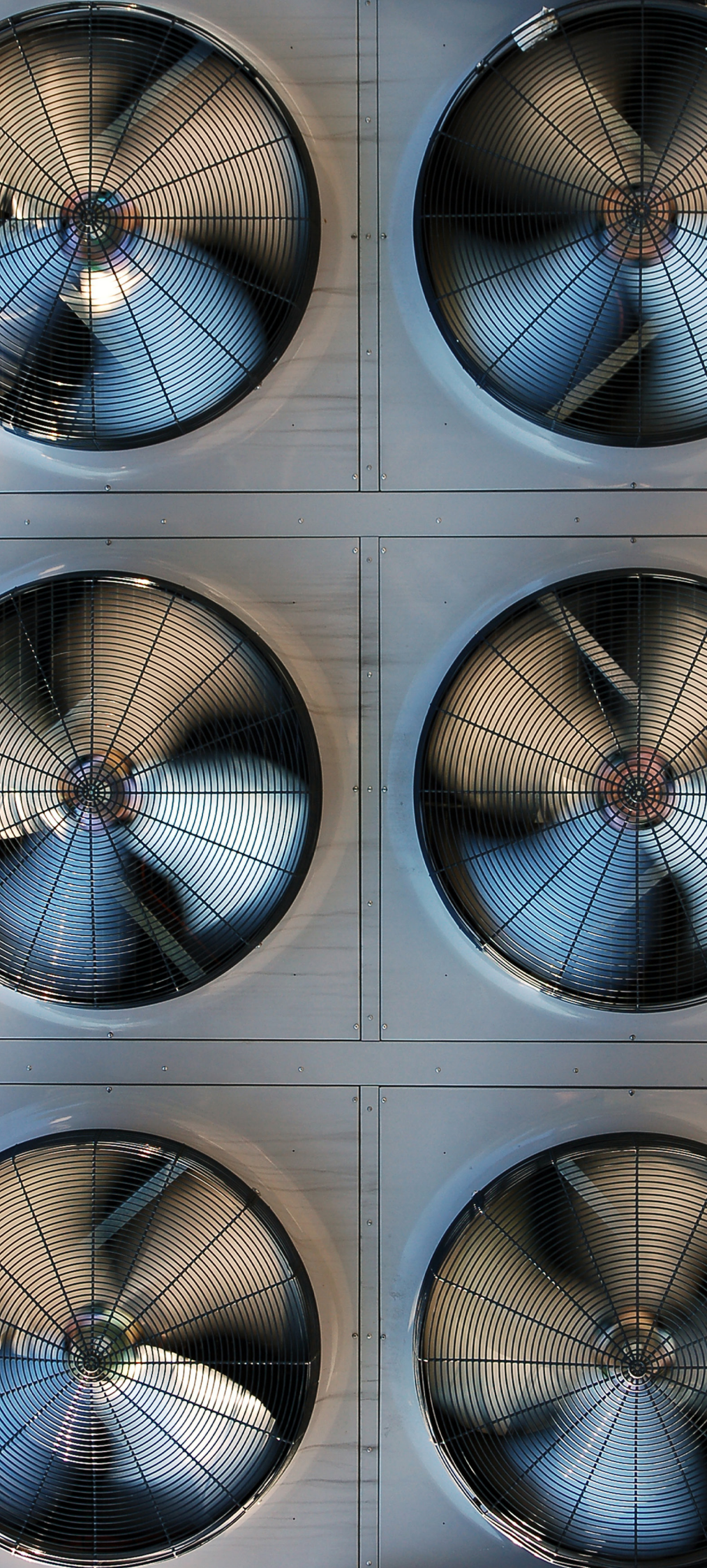

Member of Sumitomo Drive Technologies

Lafert S.p.A.

J. F. Kennedy, 43
30027 San Donà di Piave (Venezia), Italy
Tel. +39 / 0421 229 611
lafert.info@shi-g.com

www.lafert.com

Branches & Partners

Lafert GmbH

Wolf-Hirth-Straße 10
71034 Böblingen
Germany
Phone +49 175 550 4526
lge.info@shi-g.com

Lafert Electric Motors Ltd.

Unit 17 Orion Way
Crewe, Cheshire CW1 6NG
United Kingdom
Phone +44 / (0) 1270 270 022
luk.info@shi-g.com

Lafert Moteurs S.A.S.

L'Isle d'Abeau Parc de Chesnes
75, rue de Malacombe
38070 St. Quentin-Fallavier
France
Phone +33 / 474 95 41 01
lfr.info@shi-g.com

Lafert Motores Electricos, S.L.U.

Poligono Pignatelli, Nave 27
50410 Cuarte de Huerva (Zaragoza)
Spain
Phone +34 / 976 503 822
les.info@shi-g.com

Lafert N.A. (North America)

5620 Kennedy Road - Mississauga
Ontario L4Z 2A9
Canada
Phone +1 / 800/661 6413 - 905/629 1939
lna.info@shi-g.com

Lafert Electric Motors (Australia)

Factory 3, 117-123 Abbott Road,
Hallam - VIC 3803
Australia
Phone +61 / (0)3 95 46 75 15
info@lafertust.com.au

Lafert Singapore Pte Ltd

48 Hillview Terrace #06-06
Hillview Building - Singapore 669269
Phone +65 / 67630400 - 67620400
info@lafert.com.sg

Lafert (Suzhou) Co., Ltd.

No.3 Industrial Plant Building Yue Xi Phase 3,
Tian E Dang Lu 2011, 215104 Wuzong
Economic Development Zone, Suzhou
China
Phone +86 / 512 6687 0618
lsu.info@shi-g.com